



The Whalen Company

P.O. Box 1390 ▪ Easton, Maryland 21601 ▪ Tel. 410.822.9200 ▪ Fax 410.822.8926 ▪ www.whalencompany.com

INSTALLATION AND MAINTENANCE INSTRUCTIONS FOR 4-PIPE FACE AND BYPASS UNITS RISER HEAT-EXCHANGER FAN-COIL UNITS Models W204–W804

RECEIVING

Whalen room fan coil units are either shipped individually packaged in corrugated shipping containers (with internal reinforcement for the tube extensions) or palletized (multiple unboxed units strapped to a shipping skid). Palletized shipments will require a fork lift to unload the units from the truck. For ease of handling and distribution, each unit is individually tagged with a label in three places containing information found on the approved unit schedule. This tagging is located on each end of the carton and directly on the unit.

JOB #	:	20110
MODEL #	:	W404X
FLOOR	:	12
RISER #	:	21B
HAND	:	RH
COIL	:	1-1/4
HEAT SUP	:	1 1/4
HEAT RET	:	1 1/4
DISCH	:	8 X 12 F

Typical label information includes job number, unit model, riser number, floor, LH or RH riser location, riser sizing, and other information specific to the project. This identification allows units to be delivered to a particular location in a protected unopened carton.

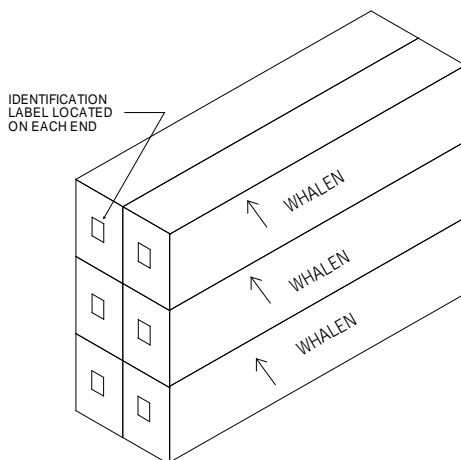

The Whalen unit consists of an outer casing, riser coils, an inner assembly, fan and motor. (Thermostats, grilles, and filters are normally shipped separately, subsequent to the units).

Upon receipt, the complete shipment should be inspected for signs of damage. Visible damage should be noted on the freight bill at the time of delivery. All shipments are F.O.B. factory; the customer or consignee must report any claim for damages, visible or concealed, directly to the freight carrier.

IMPORTANT: THE RISERS ARE NOT HANDLES! DO NOT SUPPORT OR LIFT THE UNIT BY THE PIPE EXTENSIONS.

Units may be stored in a horizontal position limiting stacking to no more than six (6) units high.

Each unit undergoes a quality control inspection and is factory tested for proper operation. It is the customer's responsibility to provide protection for the units upon arrival at the "ship to" destination. This protection includes but is not limited to vandalism and weather deterioration. The units must be protected from the elements. It is solely the customer's responsibility to protect equipment from adverse weather conditions and to take security measures against theft and vandalism on the jobsite.

INSTALLATION

It is recommended that the installation of the fan coil unit begin on the lowest floor of a riser and proceed floor by floor to the top of a riser. After removing the unit from the carton it should be placed on the floor in a horizontal position. The riser heat-exchanger coil floats within the unit assembly to allow for normal expansion and contraction. It is critical to align the units so that the proper risers match up when the units are installed. The riser piping on 4 Pipe units are as shown below (reference the project submittal drawings for the actual dimensions of your project).

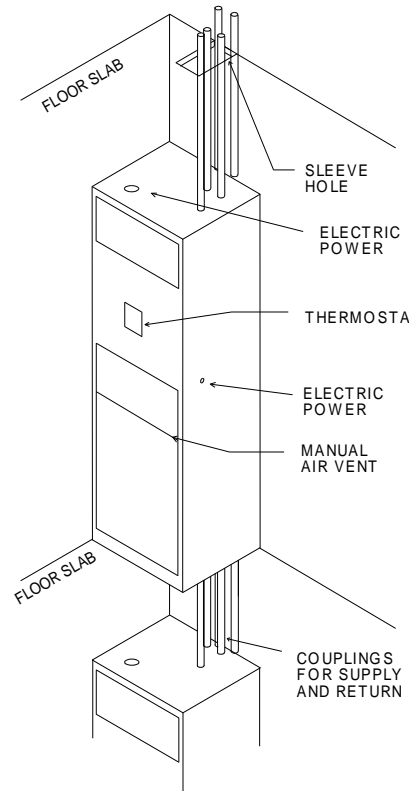
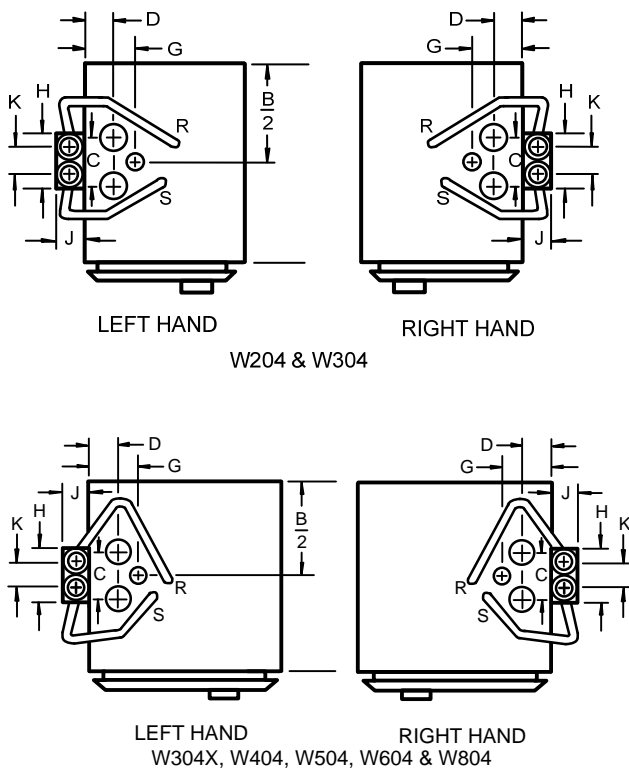

UNIT MODEL	NOM CFM	A	B	C	D	E	F	G	P	T	MINIMUM SLEEVE SIZE
W204	200	12	14	2 1/2	1 1/2	2	8	2 3/4	2 1/2	3	8 X 8
W304	300	12	14	2 1/2	1 1/2	2	8	2 3/4	2 1/2	3	8 X 8
W304X	300	14	14	4	2 3/4	2	10	4 1/2	3	4	8 X 10
W404	400	16	16	4	2 3/4	3	10	4 1/2	3	4	8 X 10
W504	500	16	16	4	2 3/4	3	10	4 1/2	3	4	8 X 10
W604	600	18	16	4	2 3/4	3	12	4 1/2	3	6	8 X 10
W804	800	18	16	4	2 3/4	3	12	4 1/2	3	6	8 X 10

All dimensions in inches.

H.W. RISER SIZE	H	J	K
3/4	3 1/8	1 1/2	1 5/8
1	3 11/16	1 13/16	1 13/16
1 1/4	4 3/16	2 1/16	2 1/16
1 1/2	4 11/16	2 5/16	2 5/16

Supply and return riser piping should extend 4" out the top of the casing (consult your project drawings for this dimension on your project). Position the pipes as necessary by gently tapping the ends with a soft wood block. With tubes positioned, measure the distance from the bottom of the drain pan (floor level) to the swaged female connections on the unit below. Allow a minimum of 1" insertion depth into the swaged connection.

Cut measured riser pipes and the condensate drain line. It is not necessary to have piping inserted the full length of any swaged connection. Deburr and clean the ends of all piping. If the project requires riser extensions due to the floor-to-floor height, this is the time that they should be measured, cut and added to the unit risers. Modifications requiring the extension or shortening of risers are the responsibility of the installing contractor.

Measure the distance between units when in place (from bottom of upper unit to top of lower unit). Cut Armaflex, or other approved closed cell, vapor seal insulation, to measured lengths plus one inch (1"). Slide over tubes. Apply recommended sealant (Armstrong 520) to upper end of Armaflex and around pipes at drain pan. Press Armaflex end to pan, insure seal, apply additional ring of sealant around connections.

Move Armaflex up around pipes, as far as possible, and clamp temporarily until soldering is complete. Clean and apply flux to both male and female ends. Tip unit upright and guide pipes through sleeve hole in floor (requires two (2) men plus third man on floor below to guide upper male tubes into wedged female tubes of lower unit) - (an appliance hand truck has been found helpful in maneuvering and positioning unit in place). Unit must be vertically aligned in two planes to assure proper condensate drainage.

Carefully position the unit so it is centered in the sleeve hole and insert the bottom of the risers into the swaged connections of the unit below. Riser piping and drain connections are soldered from floor below.

Riser joints must be made with Sil-Fos or other high temperature alloy. Soft solders or other low temperature alloys are not suitable for this application.

After piping/riser systems has been hydrostatically tested for leaks, clean piping and top of unit, remove clamps on insulation. Apply sealant around pipe at unit top and Armaflex ends, press firmly to insure bond and vapor seal, apply additional ring of sealant around joint. (If insulation is installed after soldering extreme care must be used in application to insure proper sealing of all joints. Proper adhesives must be used and vapor barrier insured).

(In coastal and humid areas, it is recommended that the condensate drain lines be insulated where pipes are in a non-air conditioned space. Drain pans are also recommended to be insulated with an approved 3/4" rigid insulation board in cases where area below unit is not air conditioned and exposed to excessively humid conditions).

Pipe chases may be further insulated with approved insulating material or foam sealed with a vapor barrier sealant.

Risers are designed to handle up to 1 inch of vertical expansion in each direction. If the total calculated riser expansion exceeds these limits, the installing contractor must provide additional means of handling expansion compensation on the riser.

Whalen units may be set and piped as soon as floors are in place, thereby allowing installation prior to other interior work. It is recommended that the grille openings be covered during construction.

IMPORTANT: All joints should be hydrostatically tested for leaks before furring-in the unit.

The shipping carton can be utilized as a protective shield by cutting the ends off the carton.

If the riser floor sleeve hole extends beyond the bottom of the unit, a sub-plate can be provided to extend beyond the unit base and cover the hole to prevent air circulation.

Units at the top of *upfeed* risers are provided with a manual air vent on the Top U-Bend assembly, which is normally accessed through the front supply grille or access panel. During testing and start-up, all "TUB" units must be vented to dislodge trapped air within the risers.

Units at the bottom of *downfeed* risers are provided with a manual drain on the Bottom U-Bend assembly, which is normally accessed through the front return grille. "BUB" units are used to drain the risers and are provided with a boiler drain and male hose bib connection.

The installing contractor is responsible for complying with all applicable building codes.

ELECTRICAL

A complete internal electrical wiring harness has been installed at the factory requiring only field connection of main power supply to the unit junction box and installation of the thermostat. All wires and thermostat wiring are color coded. Fan motor and all field electrical wiring should be performed in accordance with the National Electrical Code and any applicable local codes. Aquastats are all easily accessible through the supply or return air openings.

Electrical data can be found within the approved submittal drawings or by referencing the wiring diagram and electrical label attached to the fan cover, located inside the return air opening.

Standard unit power connection is made to a unit-mounted electrical junction box, through a 7/8" diameter opening located on either the left or right side of unit. Standard connections and clamps per local building codes should be used. Power supply need only be brought to the junction box inside the return air opening.

The power wiring configuration of the unit varies depending on the incoming voltage. The ground wire should be firmly secured to the junction box. For 115 and 265 Volt incoming power, the white line wire (Neutral) connects to the white wire in the box and the black line wire (L1) connects to the black wire in the box. For 208 / 230 Volt incoming power, the white line wire (L2) connects to the red wire(s) in the box and the black line wire (L1) connects to the black wire in the box. Connections should be secured and insulated as per local codes and ordinances. For 115 and 265 Volt units provided with a disconnect switch, connect the white line wire (Neutral) to the white wire in the control box and the black line wire (L1) connects to the open terminal on the disconnect switch. For 208 / 230 Volt units provided with a disconnect switch, connect the white line wire (L2) to the open red terminal on the disconnect switch and connect the black line wire (L1) to the open black terminal on the disconnect switch.

A wiring diagram is affixed to the fan cover of each unit. Units are all factory wired requiring only field installation of the main power supply and the thermostat.

DO NOT OPERATE THE UNIT WITHOUT THE THERMOSTAT OR RETURN AIR FILTER - TO DO SO VOIDS WARRANTY.

FINISHING

The Whalen Unit is designed for drywall to be applied directly to the unit. Screws used to fasten the drywall to the cabinet can not penetrate more than 1/4" into the unit. (For 1/2" wallboard the maximum screw length is 3/4"). Areas of the cabinet where screws might damage wiring, piping or coils are clearly marked.

Clean all drywall dust and debris from the unit after drywall installation and cutting of appropriate air and thermostat openings.

Be sure not to damage thermostat wiring or plug located in recessed junction box during this process. All cabinet openings should be covered to keep out materials that may be harmful to unit components. Unit components showing signs of foreign material such as water, dust, dirt or paint will not be covered under the equipment warranty.

If wallboard, drywall or plaster is not applied directly to the unit casing, sheet metal sleeves or ducts should be used at supply and return air openings to prevent air leakage and facilitate attachment of grilles.

VERIFY FAN INSTALLATION AND OPERATION

Prior to operation of the fan coil, the fan should be checked for proper installation and operation. The fan is located in the return air opening next to the coil and is held in place on the fan deck by two sheet metal straps that fasten together at the bottom of the fan housing with a machine screw. The fan should be held rigidly by the straps and should be positioned to the rear of the cabinet, between the flanges on the fan deck. The strap screw should be tightened fully so that the upper and lower straps make contact. The straps will have no slack when the fan is correctly installed.

GRILLES and FILTERS

Supply and return grilles and filters are shipped separately and are normally installed after finishing is complete, and the unit is cleaned of all dust and debris.

Supply grilles are attached with sheet metal screws provided.

The return air grille is furnished with two machine screws (6/32 x 1-1/4" nom), which fit into factory installed inserts on the unit.

Check the following prior to installation of the return air grille.

1. Verify that the condensate drain pan and drain line are clear from debris on all heating/cooling units.
2. A clean and properly sized return air filter is installed within the return air grille.
3. Service disconnect switch, when included, is set to "ON."

IMPORTANT: DO NOT USE SHEET METAL SCREWS TO ATTACH THE RETURN AIR GRILLE

THERMOSTAT

The thermostat is normally located on the front (return air side) of cabinet. Standard units include a recessed junction box with polarized plug for connection and unit mounting of the thermostat.

Units that utilize a field wired remote mounted thermostat will have field wiring connection made to color-coded control wiring through 7/8" diameter opening in top of cabinet, or through the left or right side of cabinet, as specified in submittal drawings.

Check to see that the thermostat provided has a model number that matches the one referenced on the wiring diagram. Attach the thermostat to the unit wiring with the polarized plug or color-coded wiring, using the connectors provided. Attach the thermostat to the unit or junction box with the screws provided.

The unit is provided with an aquastat that senses the water temperature in the hydronic system. This aquastat works in conjunction with the thermostat to put the unit in the heating mode when the water in the coil is hot and into the cooling mode when the water is cold.

Thermostats are shipped separately, individually packaged in a box that has been designed to serve as a dust cover to protect the thermostat during finishing and cleaning. Thermostats should be protected until the space is ready for occupancy.

Note: many electronic, digital and programmable thermostats are designed to work on a variety of types of units (fan coils, heat pumps, cooling only units, oil burners, etc) and require programming to be performed to match the thermostat to the type of unit and type of installation in order to properly control the unit. The Whalen Company does not perform this programming as it requires knowledge of the installation and operating parameters of the system that Whalen does not possess. This programming must be performed by the installing contractor.

DO NOT OPERATE THE UNIT WITHOUT THE THERMOSTAT OR RETURN AIR FILTER - TO DO SO VOIDS THE WARRANTY.

HYDRONIC PIPING SYSTEM CHECK

WARNING

The hydronic chilled water / hot water piping system must be clean and contain minimum oxygen levels to prevent corrosion. Condenser water pH, total dissolved solids and total suspended solids must be maintained within proper limits to prevent equipment failure. Total dissolved solids should not exceed 300 ppm. Total suspended solids should not exceed 75 ppm. PH should be between 6.8 and 8.4.

Closed loop chilled and hot water systems must each include an air separator. Water pumps, chillers or boilers and water temperature control systems must be fully operational before the units will operate correctly.

The Whalen Company cannot overemphasize the importance of insuring the chilled / hot water system is clean and fully operational before operation of the units. Almost 100% of installation problems are directly related to water systems being dirty or not operating properly.

It is recommended that all water system checks be completed before building drywalls and ceiling are installed. After the units are installed, the riser system should be thoroughly leak checked with unit cabinet water valves closed on hot water riser. All risers, supply and return, should be supplied with blow down valves at the bottom, and the risers are to be flushed clean of all debris before individual unit ball valves are opened.



After the water system has been cleaned, the hot water coils must be filled and vented (the coils and valves are accessible through the supply air opening of the unit). This is also a good time to check the condensate drain system when opening the supply and return ball valves on each coil. To purge the coils and vent trapped air pockets, open the supply riser ball valve and open the air vent located on the coil leaving water connection at the top of the coil. Vent this line until a steady stream of water is achieved. When vented, close the air vent and then open the return riser ball valve. On units provided with electric shut-off valves, manually open the electric shut-off valve while venting the coil. When venting is completed, release manual override of electric shut-off valve.

OPERATIONAL SYSTEMS CHECK

1. Place Thermostat Hi-Off-Low Fan Speed Switch to High position.
2. Set Warmer / Cooler Temperature Dial or electronic setting to 75°F and set Thermostat Auto-On Switch (if provided) to On.
3. Check to see that fan is operating and air is flowing from the discharge grille. (If not, check main power supply).
4. Move Hi-Off-Low switch to Off, then to Low position. Check air flow.
5. Depending upon the thermostat set-point, the thermostat will open or close the face and bypass dampers to satisfy the thermostat setting while the fan runs continuously. When running in cooling the face and bypass damper motor opens the damper that covers the chilled water riser and the room air flows through the riser coil and gets cooled. When the room temperature is cooled to the thermostat set-point, the face and bypass damper motor will close the damper over the chilled water riser and open the bypass damper, allowing room air to bypass the chilled water riser and pass through the hot water coil. The hot water coil is provided with an electric shut-off valve which will be held closed by the thermostat in this instance, allowing the air to pass through the hot water coil without being heated. When the room temperature falls below the thermostat set-point, the thermostat will energize the hot water valve and the air will be heated. Change the thermostat set-point to 60°F and observe that the unit

provides cold air, then change the thermostat set-point to 85°F and observe that the unit provides warm air.

When the Thermostat Auto-On switch is set to the Auto position, the fan will turn off when the room temperature reaches the thermostat setting. With the system in the cooling mode, set fan on low position, turn the thermostat dial to 60°F and allow the unit to run for two minutes. Then move thermostat set-point slowly to warmer position until it reaches the room temperature. The fan will stop.

With the system in the heating mode, set fan on low position and turn thermostat dial to 85°F and allow the unit to run for two minutes. Then move thermostat set-point slowly to cooler position until it reaches the room temperature. The fan will stop.

Once the unit has been checked out and the installer insures that thermostat and fan motor(s) are functioning properly and the unit operating satisfactorily, the tenant should be advised of the following operational procedures for satisfactory performance of the Whalen units.

OPERATING INSTRUCTIONS

Place: Hi-Off-Low Switch in Low position.

Move: Warmer/Cooler Dial to Normal.

If you desire a cooler temperature, move dial to Cooler.

If you desire a warmer temperature, move dial to Warmer.

For a fast build-up of heat or cooling, put Hi-Low switch in High.

For best results, find a position on the thermostat that you are comfortable at and leave in that position.

Hi-Off-Low switch must be in Low or High to operate. Unit will not work in Off position.

Doors and windows should be closed when system is on to prevent excess humidity in the room.

MAINTENANCE and SERVICE

The Whalen Fan-Coil unit has been designed to be as maintenance-free as possible. All replaceable parts are readily accessible via the access grilles. No special tools are necessary. It is recommended that filters be checked quarterly and replaced as required. For heating/cooling units, also inspect condensate drain line prior to and during cooling season, and assure they clear of debris.

Replacement parts are available through your local Whalen factory representative. When ordering, state the part number directly from the component in need of being replaced. Should the part number be physically absent or is otherwise unidentifiable, locate the Unit / Electrical Data Nameplate, found on the fan access cover behind return grille and take note of the unit Model Number and Serial Number. Then contact your local Whalen representative for assistance.

MOISTURE – CONDENSATE

Properly installed and insulated Whalen units present no moisture or condensate problems. Moisture evident at the outlet grille is a

temporary condition caused by excessive moisture in the room (typically caused by the room being opened to outside air). The condensation will cease when the room is closed and the relative humidity in the room brought to normal conditions.

If moisture becomes evident at the base of the unit, remove the return grille and inspect the drain pan. A clogged condensate drain line may be cleared by inserting a flexible plumber's snake into the drain connection at the bottom of the unit or by inserting the plumber's snake into the drain connection from the unit above to free any clogs in the condensate riser.

MAINTENANCE RECOMMENDATIONS

Semi-Annual

1. Inspect Unit.
2. Run system through operation check.
3. Remove return air grille and check filter; replace filter if required. (Filters may require more frequent changing in certain environments). Clean return grille as necessary.
4. Disconnect power and remove fan access cover.
5. Inspect fan and motor assembly for dirt, etc. Clean fan housing and blower wheel if required. (Whalen Units utilize permanently lubricated motors that do not require special care or maintenance when suitable air filters are installed and properly maintained).
6. Inspect drain pan, clean if necessary. Check condensate drain line to insure it is open and clear.
7. Vacuum and clean the air coil fin surface accessible through the return air opening. Using a hand sprayer, spray the face of the coil with a mixture of liquid dishwashing soap and water and rinse by spraying the face of the coil with water. Professional coil cleaning service may be required for coils with caked on dirt and grime.
8. Replace fan access cover. Restore power and replace return air grille with clean filter installed.
9. Remove and clean supply air grilles if required.

DRAIN PANS

The drain pan should be inspected before summer operation with the removal of all debris to allow the proper flow of condensate. Periodic inspection of the drain pan should be performed during the cooling operation to prevent any possibility of it becoming clogged with foreign matter. Use a bactericide or bacteriostat drain pan conditioner that is pH neutral.

The condensate riser is provided with a slip coupling just above the drain pan outlet to facilitate cleaning of the drain. When cleaning the drain line, raise the coupling up about 1" to provide access to the drain line. Clean the drain with a plumber's snake. Push the slip coupling back down to the drain outlet when cleaning is finished to help prevent debris from falling into the drain outlet.

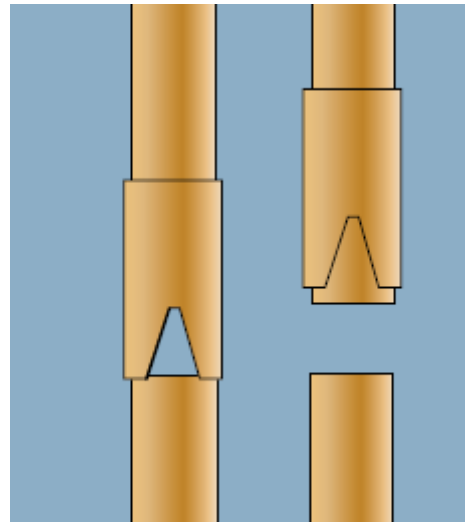

FILTER

The filter can be accessed for changing or cleaning by removing the return air grille. Standard return air grilles contain two screws located on the top and bottom of the grille. Hinged Core Return Air Grilles contain spring clips or thumb tabs located on the top corners of the grille. Removable Core Return Air Grilles contain spring clips or thumb tabs located on the top and bottom corners of the grille.

Throwaway The filter should be changed regularly with periodic inspections made to prevent the accumulation of dirt and particulate matter that can negatively affect the free flow of air. If the application or frequency of operation causes excessive dirt to accumulate, the filter should be changed more frequently.

Permanent The filter should be cleaned regularly with periodic inspections made to prevent the accumulation of dirt and particulate matter that can negatively affect the free flow of air. If the application or frequency of operation causes excessive dirt to accumulate, the filter should be cleaned more frequently.

TROUBLE DIAGNOSIS

Trouble diagnosis should only be attempted by qualified maintenance personnel. Before any troubleshooting is performed, verify that the thermostat has been programmed as required for proper operation on the unit and installation in question.

4-Pipe Face and bypass heating/cooling units

Most problems can be promptly diagnosed at the thermostat without the necessity of removing grilles or registers. The fan motor and blower are accessible and removable through the return air opening, after removal of the return grille and fan access cover. 4-Pipe heating/cooling units equipped with a two

speed fan motor will be provided with a 5 or 6-wire automatic changeover thermostat (the 6th wire is a neutral). Units with optional three speed fan motors will be provided with a 6 or 7 wire automatic changeover thermostat (the 7th wire is a neutral). Aquastats are not utilized in the 4 pipe unit. The thermostats may be line voltage or low voltage if the units are provided with 24 Volt controls.

IF FAN MOTOR FAILS TO START LINE VOLTAGE CONTROLS

1. Check main power supply, circuit breakers and panel box.
2. Set thermostat fan switch in low position. Rotate temperature setpoint dial through full range. Repeat on "HI" fan setting.
3. If fan will not run on either LO or HI, disconnect power at either the building breaker panel or unit disconnect switch.
4. Remove thermostat cover and inspect for visible indications of system ground or short. Also check for proper wiring connections between thermostat and unit, to assure colors match per wiring diagram and that insulation is intact. Check "pin" terminals for good contact on thermostats equipped with polarized quick-connect plugs.
5. Should all be in order per Step 4, restore power and use volt-ohm meter to check for correct voltage from L1.
6. If correct voltage is obtained through L1 unit wire, connect same -- using *jumper* if necessary -- to BRN (HI fan) unit wire. If motor runs at high speed, proceed to check low speed operation: L1 unit wire to RED (LO fan) unit wire. For three speed motor applications, connect the L1 wire to the ORANGE (MED fan) for medium speed check. Should motor run satisfactorily at all speeds and Steps 4 and 5 have been completed, problem is likely with thermostat. See Step 7.

If motor does not run on either red or black, check at main junction box for incoming power at circuit breaker. If power is evident, remove power at circuit breaker and remove fan housing cover. Inspect fan, check for freedom of rotation within fan scroll. If fan is rubbing against side plate, loosen the set screw on the fan hub that tightens the fan to the motor shaft and move the fan slightly to a position that is free from rubbing. Re-tighten the fan set screw on the flat of motor shaft. Re-energize system and repeat motor test.

If motor fails to run on either HI, MED or LO speeds, it is defective and requires replacement. Should a PSC type fan motor fail to run on *all speeds* or hums on HI, first check capacitor for burned/discolored wiring or shield. If found, replace capacitor and retest motor. If capacitor is OK, replace motor.

7. If thermostat is suspected of being defective, disconnect from unit and use Volt-ohm meter or test light to check for continuity through HI-Off-LO switch and Heat/Cool contacts. Set thermostat to *Coollest* and with fan switch set to HI, check for continuity through Brown and Yellow leads. Rotate dial towards "Warmer." Circuit should break when bimetal contact reaches ambient room temperature. If circuit is good, set switch to LO and check

through Red lead. (With switch set to OFF, there should be no continuity). If this test is satisfactory, proceed to check in Heating mode: Set dial to *Warmest* and test HI-LO-Off functions through Blue lead; rotate dial towards "Cooler."

Should continuity or switching functions be impaired [or thermostat fails to satisfy at Warmer/Cooler settings], install replacement thermostat and check for proper operation.

IF FAN MOTOR FAILS TO START 24 VOLT CONTROLS

1. Check main power supply, circuit breakers and panel box.
2. Set thermostat fan switch in low LOW position. Rotate temperature setpoint dial through full range. Repeat on "HI" fan setting.
3. If fan will not run on either LOW or HI, disconnect power at either the building breaker panel or unit disconnect switch.
4. Remove thermostat cover and inspect for visible indications of system ground or short. Also check for proper wiring connections between thermostat and unit, to assure colors match per wiring diagram and that insulation is intact. Check "pin" terminals for good contact on thermostats equipped with polarized quick-connect plugs.
5. Should all be in order per Step 4, restore power and use volt-ohm meter to check for correct voltage from L1. If transformer does not provide 24 volt power, check transformer 24 Volt low voltage output between blue wire and yellow wire leaving transformer. If 24 volts is not present, replace transformer.
6. If 24 volts is obtained through power wire from the unit to the thermostat (typically BLACK wire), connect this wire to BRN (HI fan) unit wire. Fan relay R1 should energize and Normally Open contact should close (verify continuity with volt-ohm meter). If motor runs at high speed, proceed to check low speed operation by connecting the 24 volt power wire to the RED (LOW fan) unit wire. Fan relay R2 (if unit has 3 speed fan, low speed relay is R3) should energize and Normally Open contact should close (verify continuity with volt-ohm meter). For three speed motor applications, connect the 24 volt power wire to the ORANGE (MED fan) for medium speed check. Fan relay R2 should energize and Normally Open contact should close (verify continuity with volt-ohm meter). If any relay fails to energize or close contacts when energized, replace relay.

Should motor run satisfactorily at all speeds and Steps 4 and 5 have been completed, problem is likely with thermostat. See Step 7.

If motor does not run on any speed, check at main junction box for incoming power at circuit breaker. If power is evident, remove power at circuit breaker and remove fan housing cover. Inspect fan, check for freedom of rotation within fan scroll. If fan is rubbing against side plate, loosen the set screw on the fan hub that tightens the fan to

the motor shaft and move the fan slightly to a position that is free from rubbing. Re-tighten the fan set screw on the flat of motor shaft. Re-energize system and repeat motor test.

If motor fails to run on either HI, MED or LOW speeds, it is defective and requires replacement. Should a PSC type fan motor fail to run on *all speeds* or hums on HI, first check capacitor for burned/discolored wiring or shield. If found, replace capacitor and retest motor. If capacitor is OK, replace motor.

7. If thermostat is suspected of being defective, disconnect from unit and use Volt-ohm meter or test light to check for continuity through HI-Off-LOW switch and Heat/Cool contacts. Set thermostat to *Coollest* and with fan switch set to HI, check for continuity through Brown and Yellow leads. Rotate dial towards "Warmer." Circuit should break when bimetal contact reaches ambient room temperature. If circuit is good, set switch to LOW and check through Red lead. (With switch set to OFF, there should be no continuity). If this test is satisfactory, proceed to check in Heating mode: Set dial to *Warmest* and test HI-LOW-Off functions through Blue lead; rotate dial towards "Cooler."

Should continuity or switching functions be impaired [or thermostat fails to satisfy at Warmer/Cooler settings], install replacement thermostat and check for proper operation.

IF CONTROL VALVE FAILS TO OPERATE

Whalen 4 pipe Riser Heat Exchanger Fan Coil Units incorporate a hot water coil, electric shut-off valve and air vent that are piped to the hot water risers. The coil, shut-off valve and vent are all accessible through the supply air opening of the unit. If the unit does not heat when in the heating mode, check the control valve operation. Set the thermostat to the heating mode and adjust set-point to call for heating. Remove the supply air grille and verify that the electric shut-off valve is open (this can be determined by the location of the override lever. If the valve is not open, check for power at the control valve actuator (Line voltage if unit has line voltage controls or 24 volts if unit has 24 volt controls) using a Volt Ohm Meter (VOM). If voltage is present and valve actuator does not actuate, replace the actuator. If no voltage is present, check the output from the thermostat and verify that correct voltage is present and that thermostat is working correctly. If no voltage is present, verify the wiring to the thermostat is ok. If the wiring is ok, replace the thermostat.

IF DAMPER MOTOR FAILS TO OPERATE

On Whalen 4-pipe units with face and bypass dampers, a damper motor system controls the operation of the damper by a positive mechanical linkage. If the damper motor fails to operate, first check the thermostat through full operational range. Remove return air grille and filter.

Make sure damper is not restricted by improperly placed filter; also check to insure that debris or plaster is not lodged in damper operation areas.

Disconnect power, remove damper linkage and block off plate. Re-energize system, rotate thermostat. If damper motor operates one way only, remove thermostat and check blue and white wires for proper connections. De-energize system; remove damper motor assembly by removing four (4) screws.

Connections made to the damper relay are numbered on the relay base. Check to see if all connections are properly made and secure. Connections are different from left and right hand units (location of coil when facing return air inlet); they should be as noted below.

DAMPER MOTOR WITH SPDT RELAY

Function and Relay Pin	LEFT UNIT HAND (LH)	RIGHT HAND UNIT (RH)
N.C.	CCW Gray	CW Yellow
N.O.	CW Yellow	CCW Gray
PWR	Black	Black
COIL	White	White
COIL	Blue	Blue