



Inteli-line® Vertical Stack Fan Coil with Slide-Out Coil Pack

A NEW INNOVATION ON A CLASSIC DESIGN

The days of limited – or no – access to the valve package in a fan coil unit are over! If you're involved in projects like hotels, apartments, condominiums, senior living centers, dormitories or others that have tight spaces, then Inteli-line® Vertical Stack Fan Coil units featuring a slide-out coil pack are the smart choice. And they're available only from The Whalen Company.

When you specify an Inteli-line® Vertical Stack Fan Coil unit with a slide-out coil pack, you get many advantages like reduced commissioning time, easier access to the drain pan and internal components, plus ease of maintenance with minimal tenant disruption.

Moreover, since we offer one of the smallest footprints in the industry along with customization capabilities including cabinet height, riser locations, handing and discharge arrangements and sizes, it means that your new Whalen units will be installed and operating in significantly less time.



Inteli-line® Vertical Stack Fan Coil Unit Capacities

Model	CFM	GPM	Cooling Capacity			
			Coil Rows	EWT (°F)	TC (Btu/hr)	SC (Btu/hr)
WRX-03	350	2.1	3	45	10,100	7,300
WRX-04	450	3.1	3	45	14,500	9,800
WRX-06	700	4.2	3	45	19,700	14,300
WRX-08	758	5.0	3	45	22,700	14,600
WRX-10	1020	6.8	3	45	33,000	23,500
WRX-12	1133	8.0	3	45	38,700	28,000

Cooling based upon 80°F DB, 67°F WB entering air temperature

Model	CFM	GPM	4-Row Cooling Capacity			
			Coil Rows	EWT (°F)	TC (Btu/hr)	SC (Btu/hr)
WRX-03	345	2.5	4	45	12,700	9,000
WRX-04	440	3.3	4	45	16,100	10,800
WRX-06	650	4.4	4	45	20,600	14,200
WRX-08	753	5.6	4	45	26,300	18,100
WRX-10	1020	7.3	4	45	35,300	25,000
WRX-12	1133	8.8	4	45	43,200	30,500

Heating based upon 70°F DB entering air temperature

General Data

	WRX-03	WRX-04	WRX-06	WRX-08	WRX-10	WRX-12
Operating Weight - Cabinet (lbs.)	135	135	153	153	184	184
Operating Weight - Chassis - 3-Row Coil (lbs.)	25	25	43	43	58	58
Operating Weight - Chassis - 4-Row Coil (lbs.)	30	30	48	48	63	63
Shipping Weight (lbs.) - Cabinet	147	147	165	165	196	196
Shipping Weight (lbs.) - Chassis - 3-Row Coil	14	20	26	33	50	56
Shipping Weight (lbs.) - Chassis - 4-Row Coil	19	25	31	38	55	61
Filter Size (in.)	13 x 24 x 1	13 x 24 x 1	15 x 28 x 1	15 x 28 x 1	21 x 36 x 1	21 x 36 x 1
Filter Quantity	1	1	1	1	1	1

Inteli-line® Vertical Stack Fan Coil with Slide-Out Coil Pack

2 Pipe Cabinet Dimensions

Model	CFM	A	B	W	H	K	P
WRX-032P	300	16	18	14	48	60	54 3/8
WRX-042P	400	16	18	14	56	68	62 3/8
WRX-062P	600	18	20	16	56	68	62 3/8
WRX-082P	800	18	20	16	60	**	66 3/8
WRX-102P	1000	24	20	22	64	**	70
WRX-122P	1200	24	20	22	68	**	74

All dimensions in inches

** 800, 1000 & 1200 ONLY AVAILABLE AS REMOTE THERMOSTAT

4 Pipe Cabinet Dimensions

Model	CFM	A	B	W	H	K	P
WRX-034P	300	16	18	14	48	60	54 3/8
WRX-044P	400	16	18	14	56	68	62 3/8
WRX-064P	600	18	20	16	56	68	62 3/8
WRX-084P	800	18	20	16	60	**	66 3/8
WRX-104P	1000	24	20	22	64	**	70
WRX-124P	1200	24	20	22	68	**	74

All dimensions in inches

** 800, 1000 & 1200 ONLY AVAILABLE AS REMOTE THERMOSTAT

2 Pipe and Optional Electric Heat with Internal Drain Pan

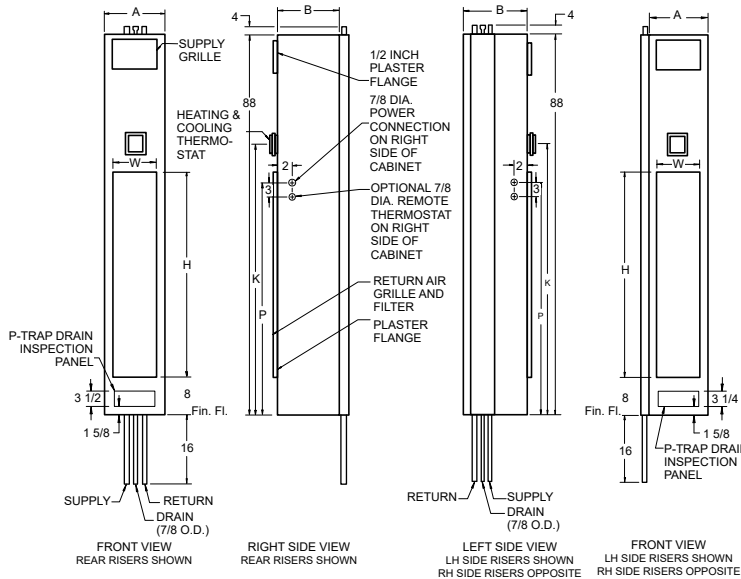

4 Pipe and Optional Electric Heat with Internal Drain Pan

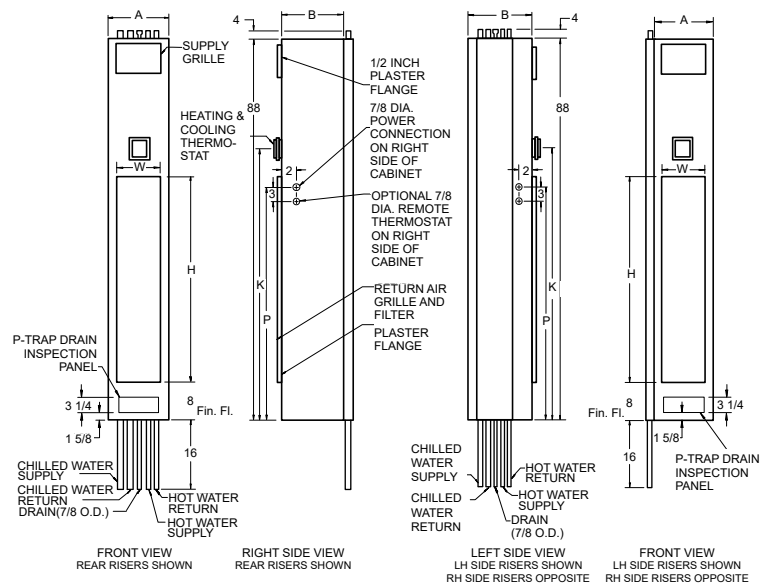

Whalen cabinet shown before the coil pack is slid in.



Coil Pack shown almost fully out of the cabinet. The flex hoses and easy access to the valve package components make equipment maintenance a snap – even if you have large hands!



Coil Pack shown halfway in/out of cabinet. The flex hoses facilitate easy slide in/slide-out functionality.



Coil Pack shown fully inside the Whalen cabinet.



P.O. Box 1390 • Easton, MD 21601 USA
whalencompany.com

Inteli-line is a registered trademark of The Whalen Company. ©2016 The Whalen Company. All rights reserved.



WL011 rev. 01-20