

Whisperline®

Cabinet Dimensions

Model	A	B	W	H	K	P
0205-**C	16	17	14	44	58	48
0305-**C	16	17	14	44	58	48
0405-**C	16	17	14	44	58	48
0505-**C	18	20	16	44	58	48
0605-**C	18	20	16	44	58	48
0805-**C	18	20	16	44	58	48
0815-**C	20	22	18	54	68	59
1005-**C	20	22	18	54	68	59
1205-**C	20	22	18	54	68	59

All dimensions in inches

Riser Length	C
9 Foot	4
10 Foot	16



Whisperline® Units with Internal Drain Rear Risers

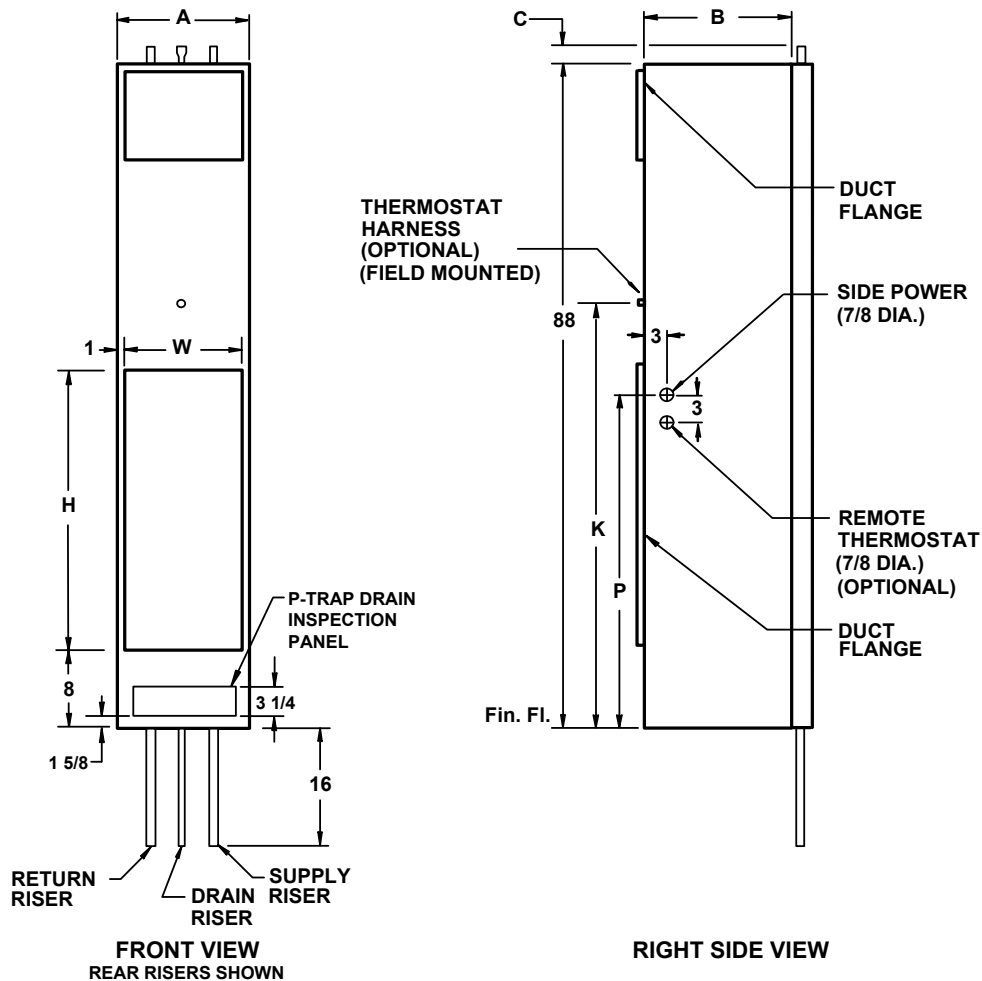

P.O. Box 1390 • Easton, MD 21601 USA
whalencompany.com

