



# Whisperline<sup>®</sup> 2-Stage Water Source Heat Pump

## VERTICAL STACK WATER SOURCE HEAT PUMP

Introducing the Whisperline<sup>®</sup> VD Series, the industry's first and only 2-stage vertical stack water source heat pump; a highly efficient unit and the ideal solution for high performance buildings. The VD Series includes a two-stage scroll compressor and an ECM Motor (electronically commutated) resulting in superior efficiency and comfort.

This series offers our customers best-in-class comfort, efficiency and low noise levels along with a wide range of available options. The Whisperline<sup>®</sup> VD incorporates a number of features and options that provide maximum comfort and performance to users and maximum flexibility to engineers and architects.



### Whisperline<sup>®</sup> 2-Stage Vertical Stack Performance

Full Load Model	CFM	GPM	Water Loop Heat Pump				Ground Loop Heat Pump			
			Cooling 86°F		Heating 68°F		Cooling 77°F		Heating 32°F	
			Capacity Btuh	EER Btuh / W	Capacity Btuh	COP	Capacity Btuh	EER Btuh / W	Capacity Btuh	COP
VDA0801**A	850	8.0	23,500	16.0	29,600	5.6	24,500	17.5	17,000	4.0
VDA1001**A	1170	9.0	30,300	15.8	41,000	5.7	31,300	16.9	22,200	3.8
VDA1201**A	1250	10.0	36,000	16.0	46,400	5.7	37,000	16.9	25,800	3.8

Part Load Model	CFM	GPM	Water Loop Heat Pump				Ground Loop Heat Pump			
			Cooling 86°F		Heating 68°F		Cooling 68°F		Heating 41°F	
			Capacity Btuh	EER Btuh / W	Capacity Btuh	COP	Capacity Btuh	EER Btuh / W	Capacity Btuh	COP
VDA0801**A	750	7.0	18,700	17.6	22,600	6.6	19,300	18.5	12,200	4.2
VDA1001**A	1000	8.0	22,700	17.5	29,500	6.2	23,400	18.0	17,600	4.2
VDA1201**A	1030	9.0	26,300	17.3	32,600	6.3	27,500	18.3	19,600	4.2

Cooling based upon 80.6°F DB, 66.2°F WB entering air temperature  
 Heating based upon 68°F DB, 59°F WB entering air temperature  
 Performance based upon 208/60/1 voltage

### General Data

	VD-A-0801	VD-A-1001	VD-A-1202
Compressor Type	Scroll	Scroll	Scroll
Compressor Quantity	1	1	1
Chassis Operating Weight (lbs.)	190	205	205
Cabinet Operating Weight (lbs.)	188	190	190
Chassis Shipping Weight (lbs.)	194	209	209
Cabinet Shipping Weight (lbs.)	186	194	194
Filter Size	22.5 x 32 x 1	22.5 x 32 x 1	22.5 x 32 x 1
Filter Quantity	1	1	1

# Whisperline® 2-Stage Water Source Heat Pump

## Cabinet Dimensions

	VD-A-0801	VD-A-1001	VD-A-1202
Width	25.6	25.6	25.6
Depth	25	25	25
Height	88	88	88

All dimensions in inches

Riser Length	C
9 Foot	4
10 Foot	15

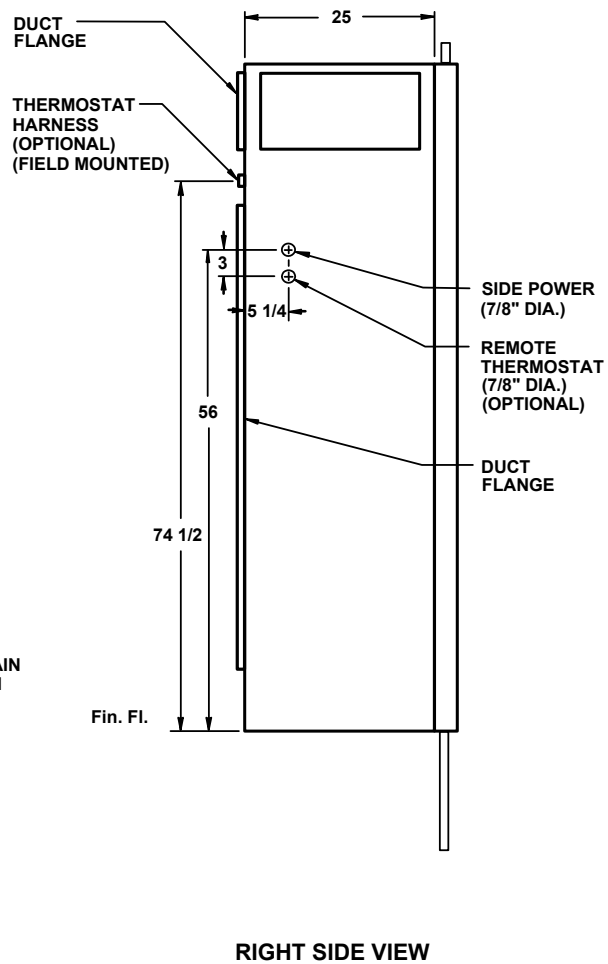
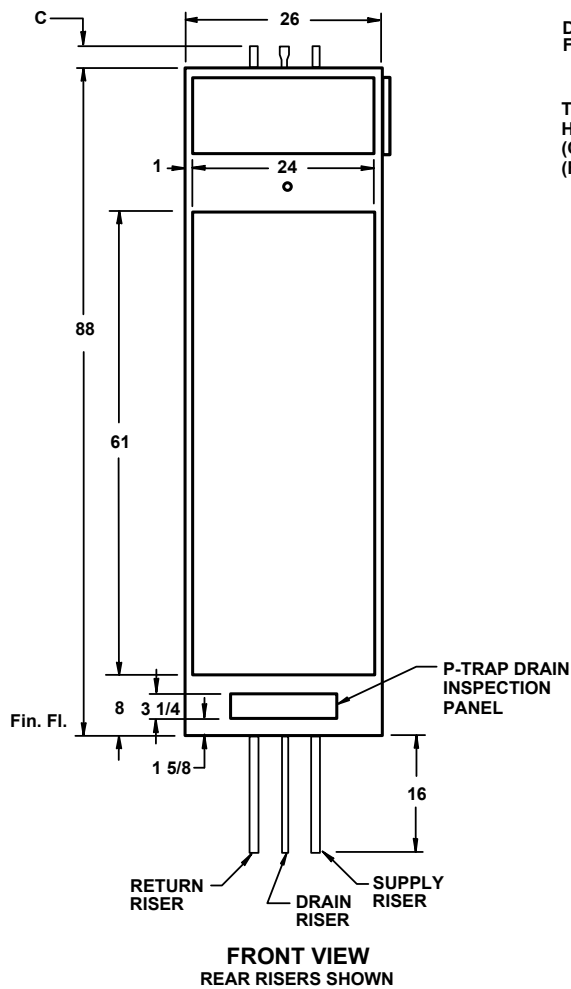

P.O. Box 1390 • Easton, MD 21601 USA  
whalencompany.com

