

PACKAGED WATER-TO-AIR HEAT PUMP

The Closetline® CAS series from The Whalen Company boasts a compact cabinet, making this heat pump system the perfect solution for commercial retrofit or new construction applications. The Closetline® CAS series far exceeds the ASHRAE 90.1 minimum efficiency and utilizes environmentally friendly R-410A refrigerant to reduce operating costs without compromising the environment. Closetline® water source heat pumps are popular in a variety of building applications where quiet operation in a compact footprint is a key requirement.

True to our commitment to offer equipment that's flexible enough to meet the design of the building rather than forcing a building to conform to limitations of the equipment, our Closetline® packaged water source heat pumps can be applied to virtually any type of building.

With a wide range of internal options, they are particularly advantageous for new construction or renovation of apartments, condominiums, hotels, senior living facilities, dormitories and office buildings.



Closetline® CAS Performance Ratings - EC Motor

Model with EC Motor	CFM	GPM	Water Loop Heat Pump				Ground Loop Heat Pump			
			Cooling 86°F		Heating 68°F		Cooling 77°F		Heating 32°F	
			Capacity Btuh	EER Btuh / W	Capacity Btuh	COP	Capacity Btuh	EER Btuh / W	Capacity Btuh	COP
CAS-006	200	2.0	6,000	17.0	7,500	4.9	6,300	17.2	4,600	3.5
CAS-009	300	2.5	9,000	14.0	11,500	4.4	9,630	15.5	7,000	3.4
CAS-012	400	3.0	12,500	13.5	15,000	4.5	13,000	14.5	10,000	3.4
CAS-015	500	3.8	15,000	17.0	18,000	5.6	15,000	19.0	12,000	4.0
CAS-018	600	4.5	18,000	17.0	21,600	5.6	18,500	19.0	13,500	4.0
CAS-024	800	6.0	24,000	16.4	28,000	5.2	25,000	18.5	17,000	3.7
CAS-030	1000	7.5	30,000	16.0	34,000	5.0	30,000	17.5	23,000	3.6
CAS-036	1200	9.0	36,000	17.0	43,000	5.0	36,000	19.0	28,000	3.6
CAS-042	1400	10.5	42,000	15.0	49,000	4.6	43,000	17.0	33,000	3.5
CAS-048	1600	12.0	48,000	15.0	56,000	4.6	49,000	17.0	35,000	3.5
CAS-060	2000	15.0	58,000	15.0	72,000	4.6	59,000	17.0	49,000	3.5
CAS-072	2200	18.0	71,000	15.0	78,000	4.2	72,000	17.0	53,000	3.0

Cooling based upon 80.6°F DB, 66.2°F WB entering air temperature. Heating based upon 68°F DB, 59°F WB entering air temperature.

Closetline® CAS Series

Closetline® CAS Horizontal Dimensions

Horizontal Right Return	Overall Cabinet			Blower Discharge Supply	
	W	H	D	X	Y
Unit Sizes	Width	Height	Depth	Supply Width	Supply Height
CASH006	20.00	11.50	34.00	10.75	6.75
CASH009	20.00	11.50	34.00	10.75	6.75
CASH012	20.00	11.50	34.00	10.75	6.75
CASH015	22.00	17.00	43.00	12.00	8.12
CASH018	22.00	17.00	43.00	12.00	8.12
CASH024	22.00	17.00	45.00	13.50	9.25
CASH030	22.00	17.00	45.00	11.00	10.75
CASH036	22.00	19.00	55.00	14.50	10.75
CASH042	22.00	22.00	55.00	12.25	11.80
CASH048	25.00	22.00	55.00	12.25	11.80
CASH060	25.00	22.00	55.00	15.00	11.80
CASH072	28.00	24.00	67.00	15.12	13.85

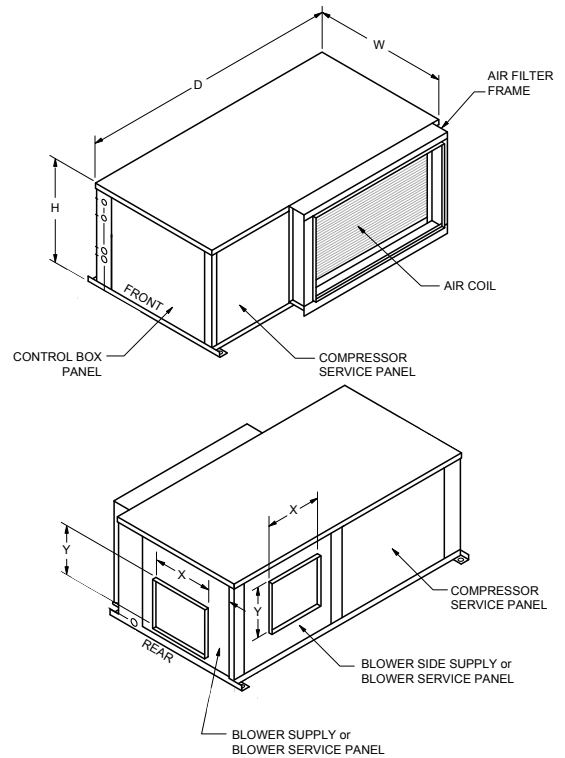

Closetline® CAS Vertical Dimensions

Vertical Right Return	Overall Cabinet			Blower Discharge Supply	
	W	D	H	X	Y
Unit Sizes	Width	Depth	Height	Supply Width	Supply Height
CASV006	19.00	19.00	24.00	10.75	6.75
CASV009	19.00	19.00	24.00	10.75	6.75
CASV012	19.00	19.00	24.00	10.75	6.75
CASV015	22.00	22.00	36.00	12.00	8.13
CASV018	22.00	22.00	36.00	10.5	9.31
CASV024	22.00	22.00	40.00	10.25	11.80
CASV030	25.00	26.00	40.00	11.13	10.75
CASV036	25.00	26.00	45.00	11.50	11.80
CASV042	25.00	26.00	45.00	12.25	11.80
CASV048	25.00	32.00	45.00	12.25	11.80
CASV060	25.00	32.00	45.00	12.75	13.85
CASV072	26.00	32.00	61.00	15.13	13.85

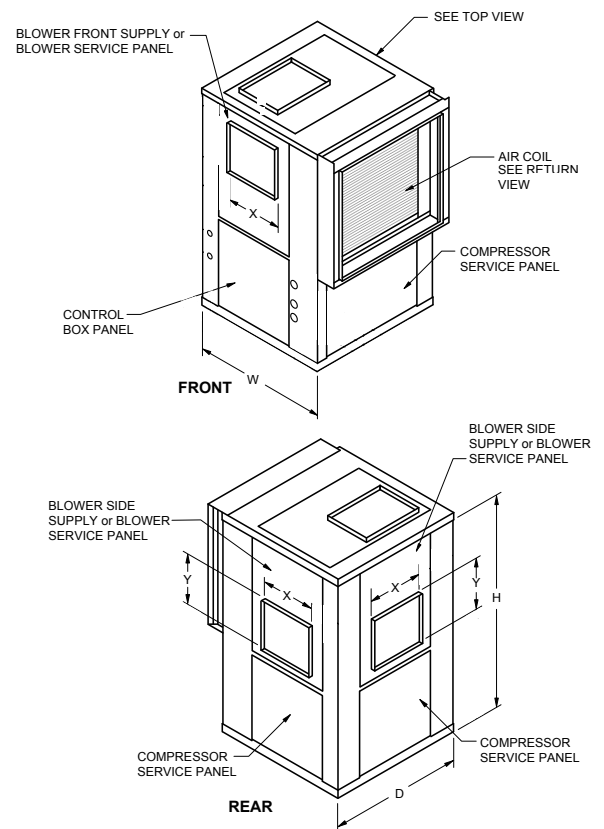

P.O. Box 1390 • Easton, MD 21601 USA
whalencompany.com

